

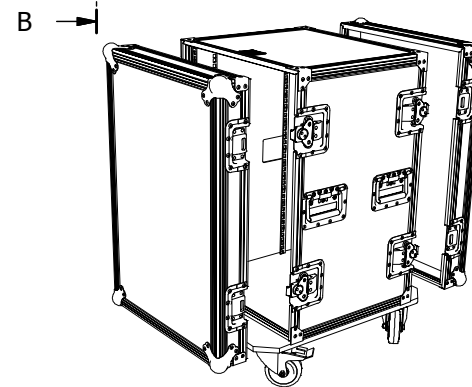

A-A (1 : 15)

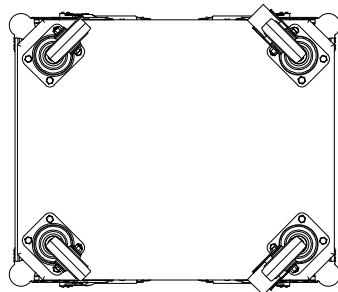

External Dimensions (excluding hardware): 516w x 633D x 740H

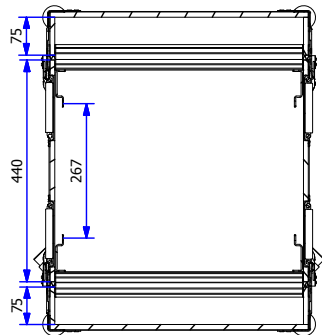

Parts List	
QTY	DESCRIPTION
8	T-Bracket B1131
8	L-Bracket 4043
8	Large Ball Corner 4101
4	Recessed Flip Handle 34082 + Backplate 34093
8	Large Padlocking Butterfly Catch L935/530/10
1	18mm Ply Castor Board
2	100mm Castor 3470 swivel
2	100mm Castor 3477 braked
4	Double Full Hole Rackstrip R0883
1	Dragon Badge

Drawing no: <b>F1916USTD</b>	Issue/Sheet 1 / 1	Wall Thickness: <b>10mm</b>	Wall Colour/Material: <b>10mm laminate/phenol faced ply</b>	Hardware Details: See parts list.	Specifications: 1. Aluminium extrusions riveted through wall material every 100mm. 2. Bifurcated rivets to be used wherever possible. 3. All hardware zinc plated. 4. No foam. 5. Rack rails front + rear. 6. Estimated weight - 36.8kgs.	ALL DIMENSIONS IN MILLIMETRES 3+4 ANGLE PROJECTION DO NOT SCALE	THIS DRAWING IS COPYRIGHTED BY DRAGON CASES. IT MUST NOT BE COPIED OR DISCLOSED WITHOUT CONSENT OF THE OWNER	 <b>DRAGON CASES</b> in partnership with Nomad PLC tel: 01633 791590 fax: 01633 791531
Title: <b>16u Standrad Rack Flightcase with 440mm Sleeve</b>		Drawn by: <b>J.B.</b>	Company: <b>AN Other</b>					
		Date: <b>09/10/2008</b>						



External Dimensions (excluding hardware): 516w x 633D x 740H

Parts List	
QTY	DESCRIPTION
8	T-Bracket B1131
8	L-Bracket 4043
8	Large Ball Corner 4101
4	Recessed Flip Handle 34082 + Backplate 34093
8	Large Padlocking Butterfly Catch L935/530/10
1	18mm Ply Castor Board
2	100mm Castor 3470 swivel
2	100mm Castor 3477 braked
4	Double Full Hole Rackstrip R0883
1	Dragon Badge

Drawing no:	18324	Sheet:	1 2	Wall Thickness:	10mm	Wall Colour/Material:	10mm laminate/phenol faced ply	Hardware Details:	See parts list.	Specifications:	<ol style="list-style-type: none"> <li>1. Aluminium extrusions riveted through wall material every 100mm.</li> <li>2. Bifurcated rivets to be used wherever possible.</li> <li>3. All hardware zinc plated.</li> <li>4. No foam.</li> <li>5. Rack rails front + rear.</li> <li>6. Estimated weight - 36.8kgs.</li> </ol>	ALL DIMENSIONS IN MILLIMETRES  DO NOT SCALE	THIS DRAWING IS COPYRIGHTED BY DRAGON CASES. IT MUST NOT BE COPIED OR DISCLOSED WITHOUT CONSENT OF THE OWNER	 <b>DRAGON CASES</b> in partnership with Nomad PLC tel: 01633 791590 fax: 01633 791531
Title:	16u Standard Rack Flightcase with 440mm Sleeve			Drawn by:	J.B.	Company:	AN Other							
Date:	9/10/08													